

COMPACT DOUBLE SPRING SIGN STANDS FOR ROLL-UP SIGNS

MASH APPROVED



Model SS340A

- Holds roll-up signs 36" & 48"
 - universal compact sign clamp, zinc plated steel, grabs and tightens on roll-up rib
- Automotive grade, steel double spring
 - designed to perform in extreme weather conditions without fatiguing or breaking
 - E-coated for maximum rust and corrosion resistance
- Legs are extendable
 - lock in multiple positions to adjust to uneven ground
- Non-skid rubber feet
- Replacement parts and assemblies available
- MASH Accepted for 48" roll-up signs, WZ-353
- Meets MUTCD Standards

Universal Sign Clamp for Roll-Up Signs
(patent pending)

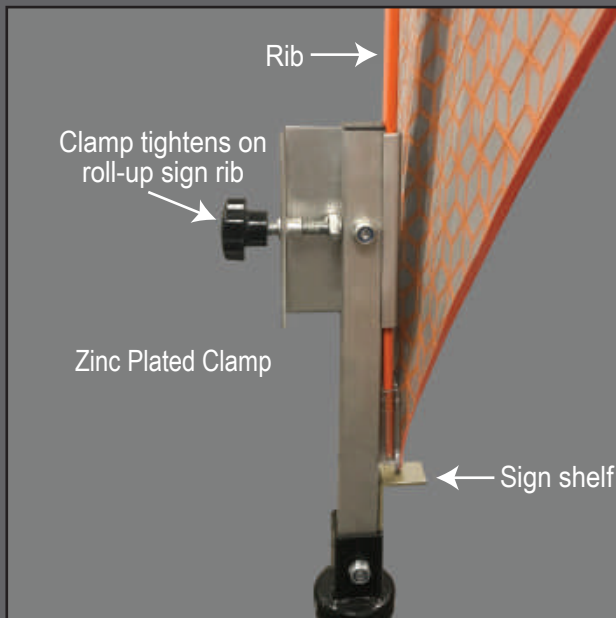

Heavy Duty
Double Spring

PLASTICADE®

Plasticade.com

TF053 Rev. 5

COMPACT DOUBLE SPRING SIGN STANDS FOR ROLL-UP SIGNS

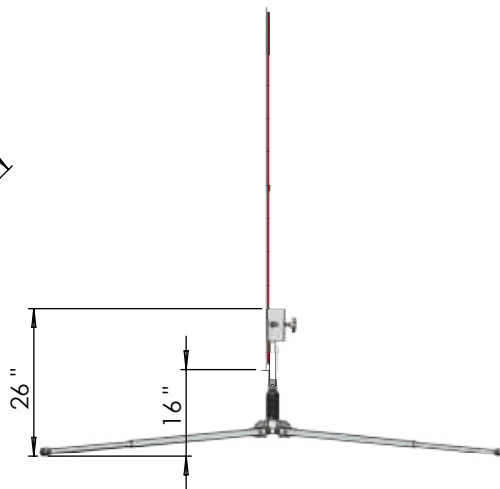
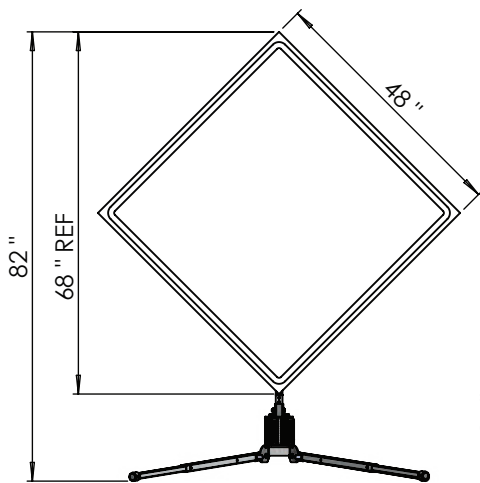
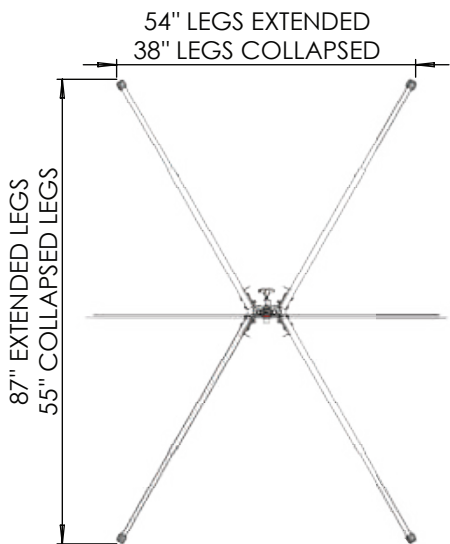

Specs

Material	Aluminum
Model	SS340A
Sign Mounting Height	16" from ground
Top of 48" Sign	82" H maximum
Carton Size	7.25" x 8.5" x 32.5"
Size Open legs collapsed footprint	38" x 55"
Size Open legs fully extended footprint	54" x 87"
Weight	27 lbs.
Included Bracket	Universal Roll-Up Sign Clamp

LEG RELEASE SYSTEM

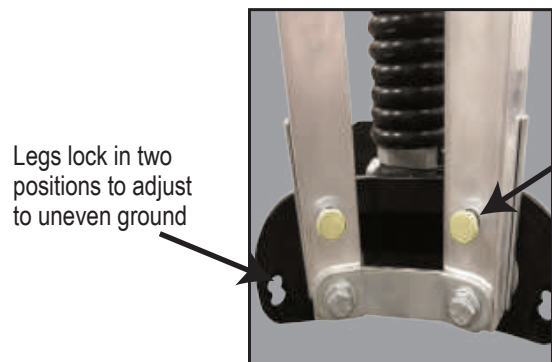

Pin Release

Step-on Leg Release

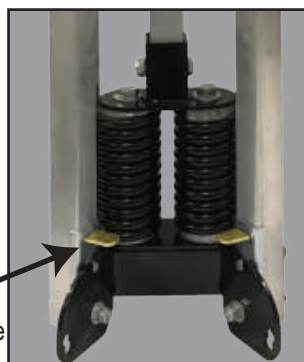

TRAFFIC SAFETY WAREHOUSE
The Best in Safety for Less

TrafficSafetyWarehouse.com

(847) 966-1018