

# 4' Parking Stop

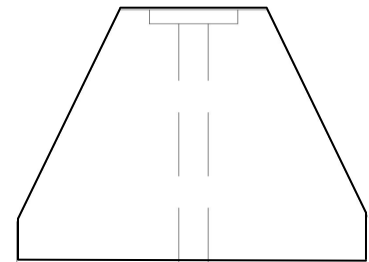
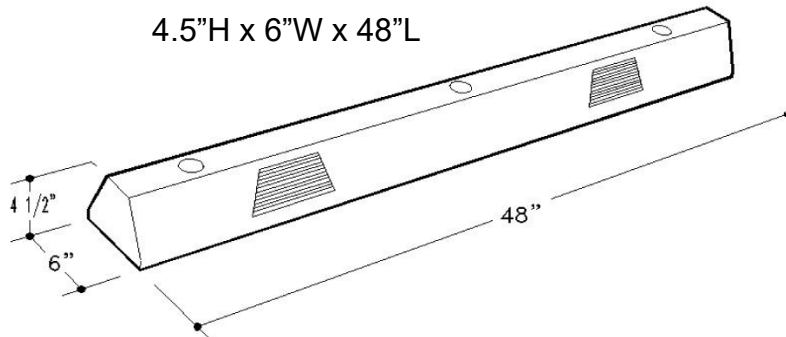

End View

Part # ST-4Y

## Hardware

Asphalt or gravel: 14" x 1/2" rebar spike with 5/8" washer Concrete: 6" lag bolt with 2" lag shield and 1/2" washer

Suggested Asphalt Installation Hardware - (3) XASPHALT per Parking Stop

Suggested Concrete Installation Hardware - (3) XCONCRETE-ST per Parking Stop

Use 10 ounce of epoxy or construction adhesive

(ie. Polyurethane PL Premium) for installations where no hardware is allowed.

## NOTES:

1. WEIGHT: 30 lbs.
2. DIMENSIONS AND FEATURES ARE REPRESENTATIVE AND NOT GUARANTEED. FOR CRITICAL APPLICATIONS A SAMPLE OF CURRENT PRODUCTION PARTS SHOULD BE EVALUATED.

**TRAFFIC SAFETY WAREHOUSE**  
The Best in Safety for Less

TrafficSafetyWarehouse.com

(847) 966-1018