

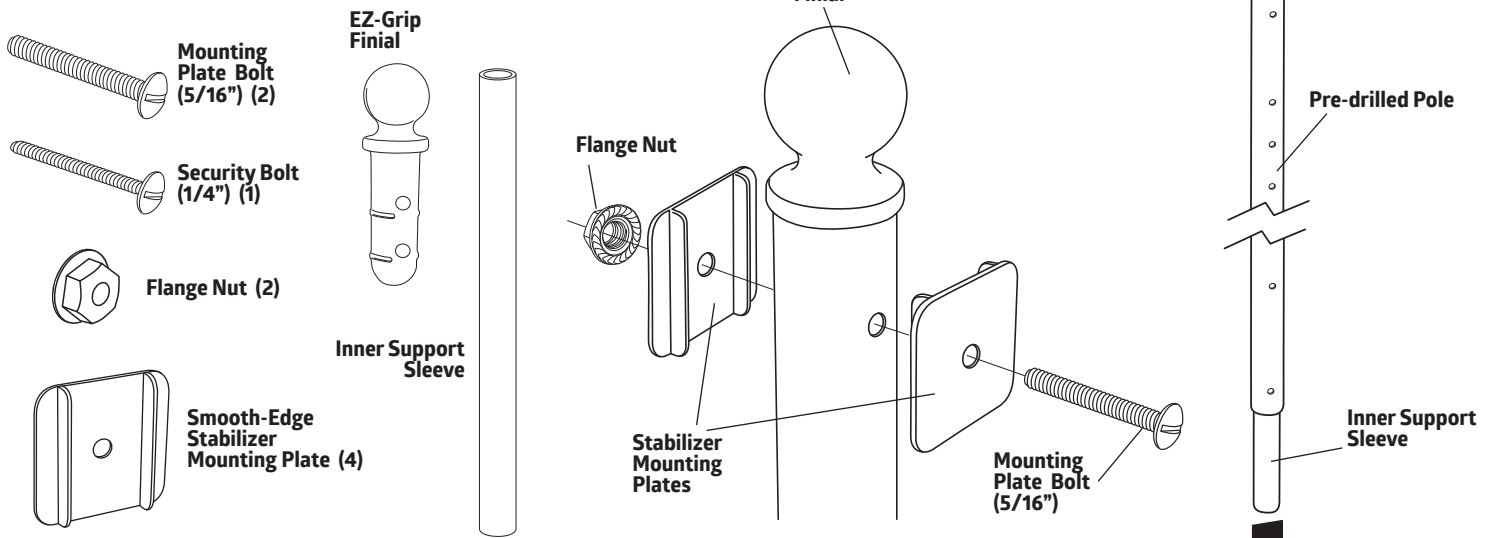

Portable Pole XL-PP3 Sign Holder

USER GUIDE



1. Insert **Inner Support Sleeve** into center hole of **Sign Base** making sure that it sits on the alignment pin inside the bottom of base.
2. Insert the pre-drilled **Sign Pole** over the **Inner Support Sleeve** and through the center hole of **Base**. It will line up on the alignment pin. Make sure the end of the pole with the 6 mounting holes is facing up.
3. Put the **Security Bolt** into the hole on the side of the **Sign Base** and then rotate the **Pole** so that the holes line up with the **Bolt**. Screw in firmly making sure that it fits in the hole in the Pole. The **Pole** may need to be turned or lifted slightly to ensure that the **Security Bolt** is properly seated. Do not overtighten.
4. For increased stability and wind resistance add 5-7 gallons of water to the base using the **Ballast Port** for 48", 60" and 72" poles. Use 7-8 gallons for 84" and 96" poles. The complete sign will weigh 35-50 lbs.. 30-40 pounds of sand can be substituted for the water.
5. Insert the **EZ-Grip Finial** into the top of the **Sign Pole** and align the holes in the pole with the holes in the **Finial**. Most signs require the finial to be inserted all the way; for signs with the hole 3" from the top of the sign use the bottom hole on the **Finial**.
6. Attach the top of the sign face to the top hole in the **Sign Pole** using the hardware provided. Make sure to place the **Stabilizer Plate** between the back of the sign and the **Sign Pole** with the flat side facing the sign and the rails running along the length of the **Sign Pole**. The **Mounting Plate Bolt** will go through the **Pole**

and the **Finial**. Attach a **Stabilizer Plate** to the end of the **Mounting Bolt** projecting out of the Sign Pole and finger-tighten the **Flange Nut**.

7. Attach the bottom of the sign face to the **Sign Pole** using the hardware provided following the same directions in step 6. You may have to wiggle the sign to align the holes that are on 3" centers starting 9" from the top hole.
8. Tighten the **Flange Nuts** snugly; Do Not over-tighten, crush or distort the **Sign Pole**. The **Flange Nuts** have serration's that will hold tight.
9. For 2 sided signs place the second sign face between the back **Stabilizer Plate** and the **Flange Nut**. For thick sign panels a longer 5/16" bolt may be required.
10. To move the sign simply grip the **Finial** handle, tip the sign on its recessed wheels and pull to roll in, out or about.

NOTE: The 'TIP-N-ROLL'™ **Portable Pole XL-3 Sign Holder** accommodates all stock street, safety, directional and other signs from 9"x12" to 24"x24" along with custom shaped sign panels as long as they have 3" hole spacing. POP pole signs that attach with zip ties can also be used.

CAUTION: 'TIP-N-ROLL'™ **Portable Pole XL-3 Sign Holders** are designed to withstand winds up to 30-40 mph. In the event of higher winds bring sign inside or add more ballast.

Prices and specifications subject to change without notice.

Manufactured by **Joseph Struhl Company, Inc.** PO Box N, Garden City Park, NY 11040
1-800-552-0023 · 516-741-3660 · Fax 516-742-3617 · www.magicmaster.com

Inst: XL-PP3 inst © 2020 Joseph Struhl Company, Inc.