

Standard 6' Speed Bump 2.5" High

Hardware installation holes are drilled with a 1/2" drill bit.
 Hardware available:
 Asphalt or gravel: 14" x 1/2" rebar spike with 5/8" washer
 Concrete: 4 1/2" lag bolt with 2" lag shield and 1/2" washer

Use 10 ounce of epoxy or construction adhesive
 (ie. Polyurethane PL Premium) for installations where no
 hardware is allowed.

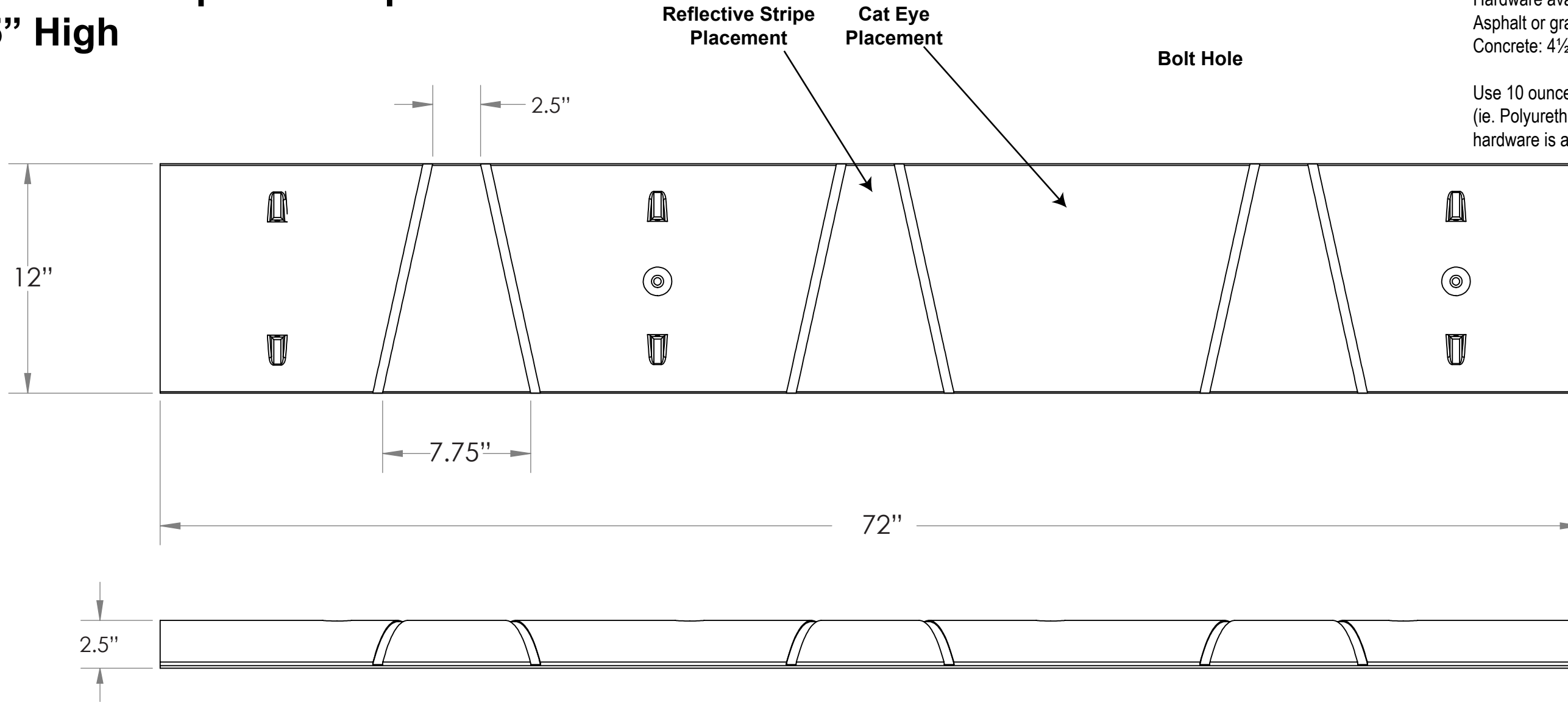

Parts:
SB72N
SB72N-S
SB72N-SE

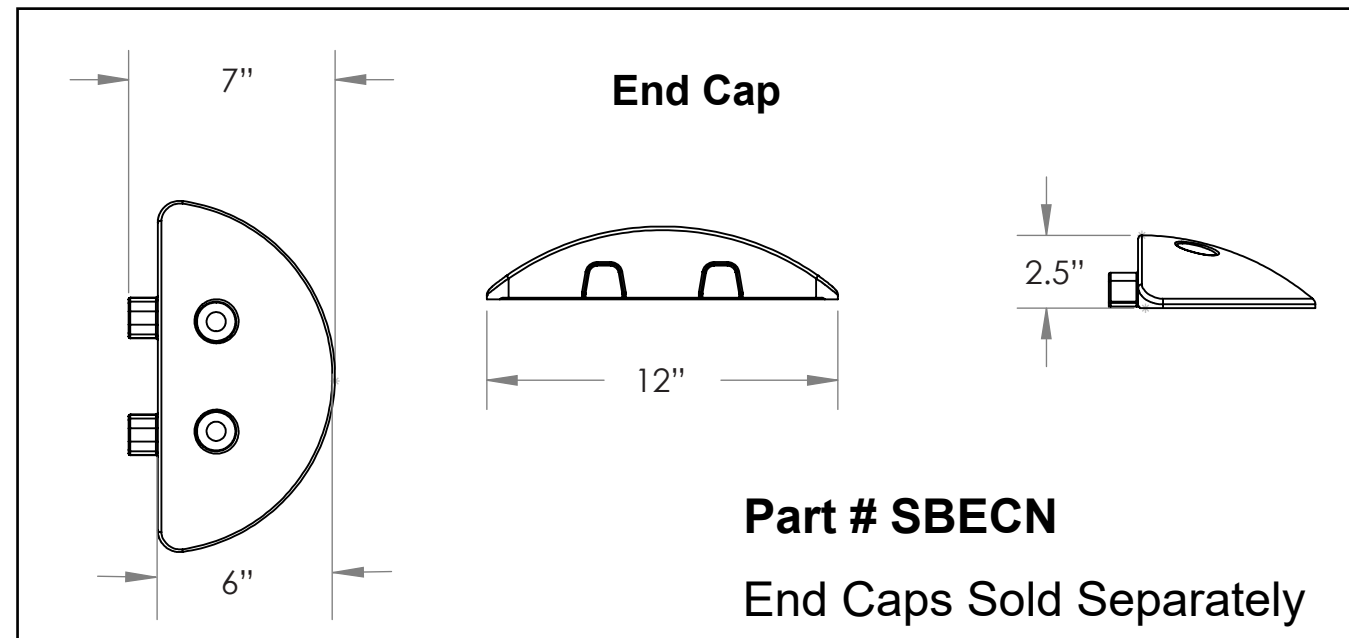
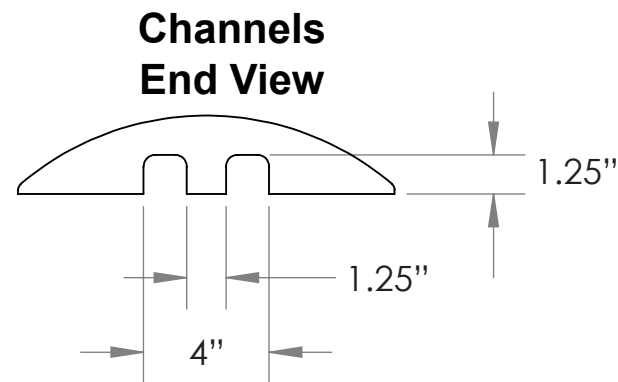

Part # SBECN
 End Caps Sold Separately

NOTES:

1. WEIGHT: 52 lbs. without end caps. Endcap Weight: 3.5 lbs.
2. DIMENSIONS AND FEATURES ARE REPRESENTATIVE AND NOT GUARANTEED. FOR CRITICAL APPLICATIONS A SAMPLE OF CURRENT PRODUCTION PARTS SHOULD BE EVALUATED.