

# Low Profile 6' Speed Bump

## 2" High

Hardware installation holes are drilled with a 1/2" drill bit.  
 Hardware available:  
 Asphalt or gravel: 14" x 1/2" rebar spike with 5/8" washer  
 Concrete: 4 1/2" lag bolt with 2" lag shield and 1/2" washer

Use 10 ounce of epoxy or construction adhesive  
 (ie. Polyurethane PL Premium) for installations where no  
 hardware is allowed.

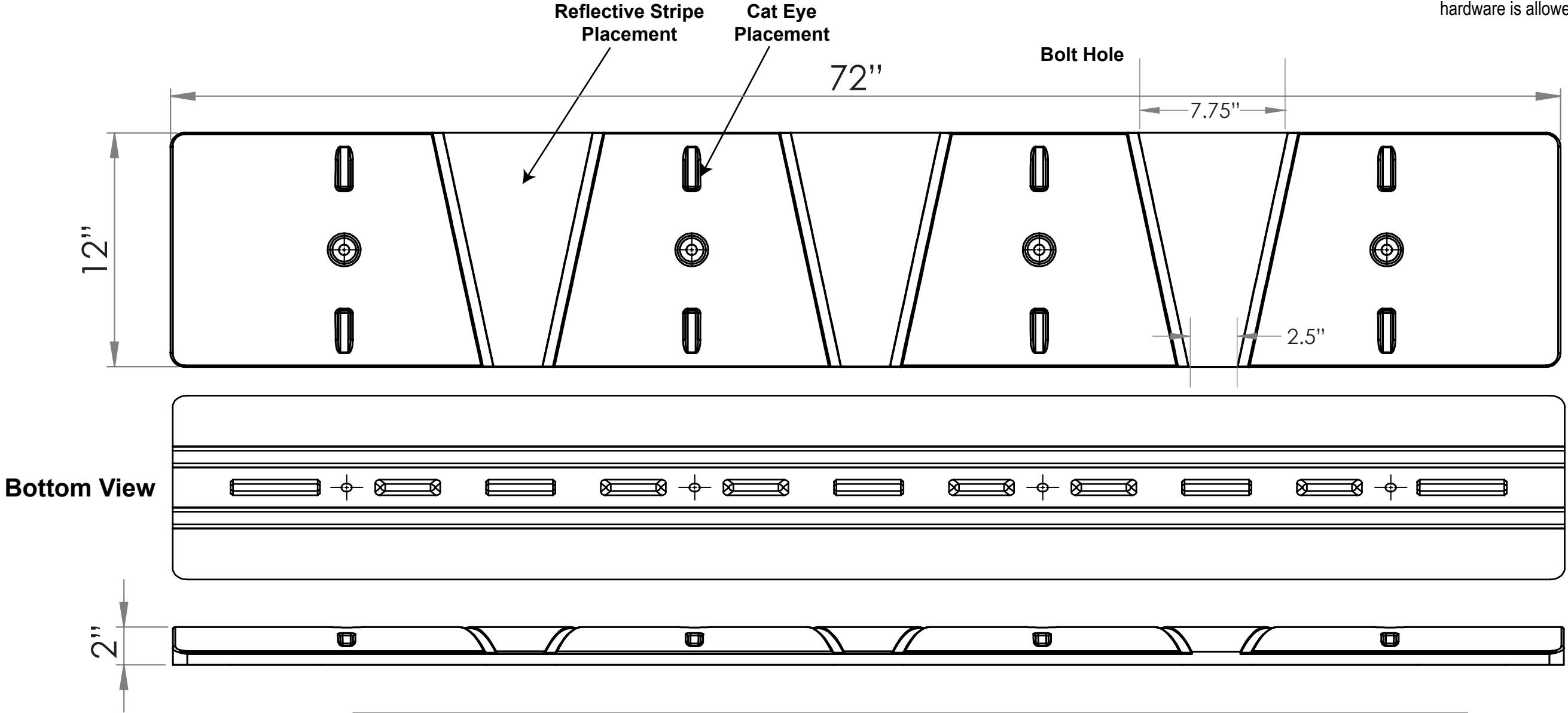

**Parts:**  
**SB72-2H-S**  
**SB72-2H-SE**

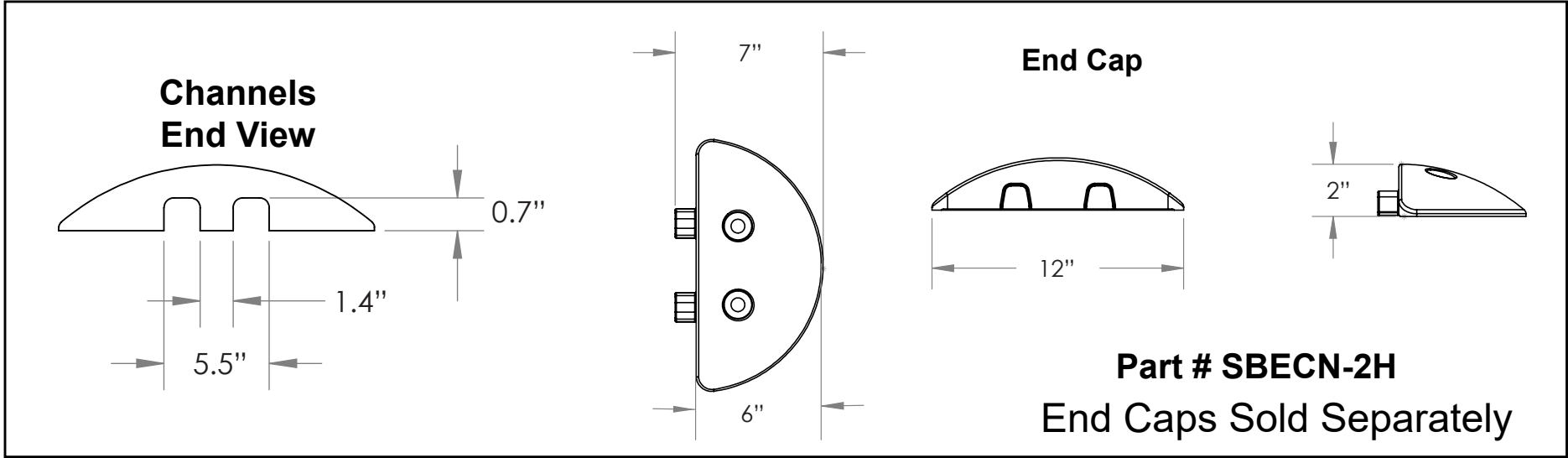

**Notes:**  
 Weight: 40 lbs. without end caps.  
 Endcap Weight: 2.25 lbs.

DIMENSIONS AND FEATURES ARE REPRESENTATIVE  
 AND NOT GUARANTEED. FOR CRITICAL  
 APPLICATIONS A SAMPLE OF CURRENT  
 PRODUCTION PARTS SHOULD BE EVALUATED.